

# *Olympus*

Alu-Tech Bodyshell



FOR YOUR HOLIDAYS OF A LIFETIME  
[www.baileyolympus.co.uk](http://www.baileyolympus.co.uk)





# BAILEY OLYMPUS

– FOR YOUR HOLIDAYS OF A LIFETIME

*Olympus is a leisure vehicle that allows you to enjoy life to the full.*

*Providing performance and value in equal measure, it is a caravan that will make you re-think where and when you choose to get away from it all.*

**Olympus – For your holidays of a lifetime**

# Olympus

Alu-Tech Bodyshell



## PRODUCT DEVELOPMENT

*To bring a product as innovative as Olympus to market it has been necessary to implement the most comprehensive test and validation programme ever undertaken for a new touring caravan.*

For over two years, the Bailey Development Team has subjected Alu-Tech built caravans to a series of accelerated life tests to enhance their structural durability and thermal capabilities at the Millbrook Proving Ground – the first choice facility of the global automotive industry.

Additional research carried out by The University of Bath – the leading independent authority in the field of towing dynamics – into body shell strength and stability has ensured that every aspect of the design has been thoroughly evaluated.

The result is a caravan that is a triumph of engineering and technological advancement. A product that it is so unique that it has necessitated the commissioning of over **one hundred bespoke tools** to build it, with a design so advanced that it has **five new patents pending**.

*Olympus – one day, all caravans will be made this way.*

Alu-Tech Development Partners



UNIVERSITY OF  
**BATH**

# ALL WEATHER VEHICLE

The new Bailey  
Olympus, featuring the  
Alu-Tech body shell,  
allows you to holiday  
all year round –  
whatever the weather.

Thicker body shell panels featuring superior grade polystyrene, and extra insulation to pipe runs and wheel boxes have greatly enhanced the thermal properties of the caravan. As a result Alu-Tech built caravans are the first to achieve the **Grade III Classification of Thermal Insulation for EN1645-I**, keeping you warm in winter and cool in summer, as well as making your caravan more economical to own.

Engineered to ensure it remains weatherproof and structurally sound, the Alu-Tech body shell sets new standards in durability. A new design interlocking external framework helps reduce the number of external joints and fixing points by 90%, thus minimising the number of potential water access points and improving the overall integrity of the protective shell.

While timber free body shell panels, featuring a composite plastic internal skeleton and low absorbency buffer zones surrounding windows and doors offer a second line of defence, limiting the impact any possible ingress may cause.

So confident are we of the performance of this new shell that it comes supplied with a market leading **ten year integrity guarantee\*** - thus providing you with additional peace of mind by protecting your investment.

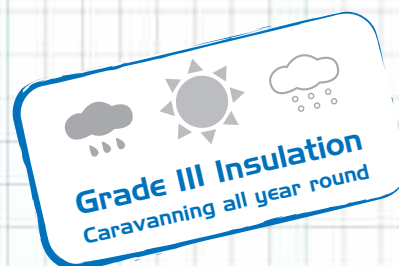

\*Terms and conditions apply (visit [www.baileyolympus.co.uk](http://www.baileyolympus.co.uk) for more information on the Olympus warranty package)

[www.baileyalu-tech.co.uk](http://www.baileyalu-tech.co.uk)



### SIDE CONSTRUCTION 1

FIRST LINE OF DEFENCE  
- INGRESS PREVENTION

90% REDUCTION IN THE NUMBER OF  
EXTERNAL JOINTS & FIXING POINTS

NO EXTERIOR  
FIXING POINTS FOR  
ALUMINIUM EXTRUSION  
FRAMEWORK

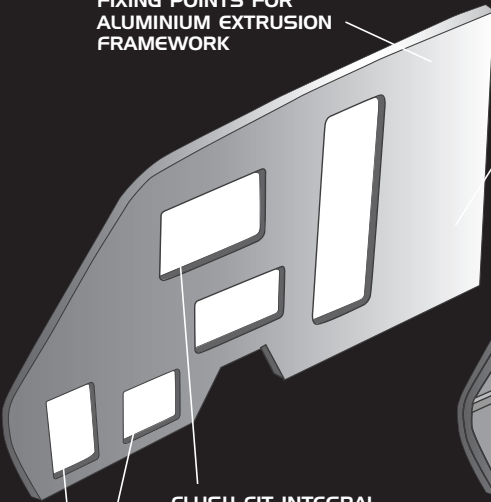

FLUSH FIT INTEGRAL  
POLYVISION DOUBLE  
GLAZED WINDOWS

FLUSH FIT INTEGRAL EXTERIOR  
SERVICE DOORS

### SIDE CONSTRUCTION 2

SECOND LINE OF DEFENCE  
- INGRESS MANAGEMENT

TIMBER FREE PANEL CONSTRUCTION

HIGH DENSITY  
POLYSTYRENE  
INSULATION

IMPACT RESISTANT  
3000 SERIES  
SINGLE SHEET  
ALUMINIUM SKIN

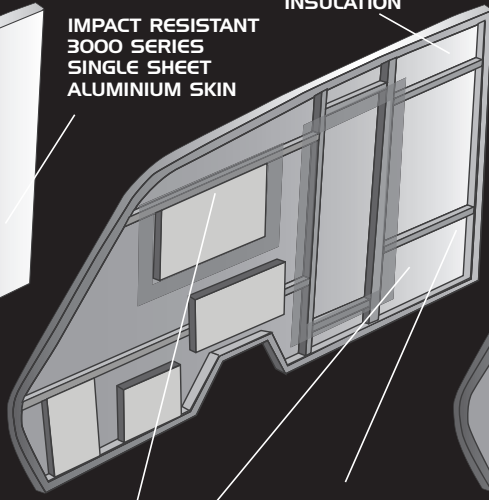

COMPOSITE PLASTIC  
INTERNAL SKELETON

LOW ABSORBENCY BUFFER ZONES  
SURROUNDING WINDOW AND DOOR  
APERATURES

### SIDE CONSTRUCTION 3

SECOND LINE OF DEFENCE  
- INGRESS MANAGEMENT

TIMBER FREE PANEL CONSTRUCTION

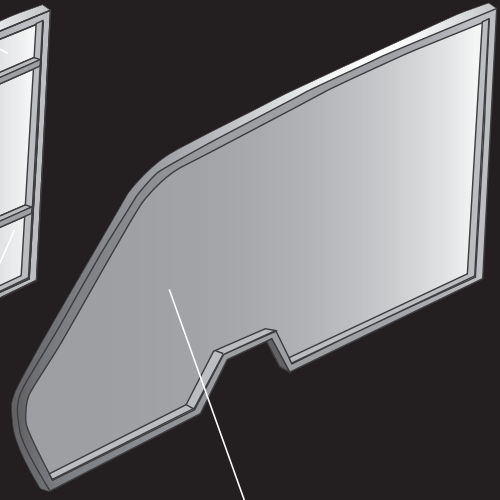

EASY CLEAN SINGLE SHEET  
GRP INNER WALL

SIDE PANEL THICKNESS = 37MM V 28MM  
IN CLASSIC CONSTRUCTION (30% THICKER)  
CEILING PANEL THICKNESS = 37MM V 31MM  
IN CLASSIC CONSTRUCTION (20% THICKER)

# ALL TERRAIN VEHICLE

## The new Bailey Olympus really is the "go anywhere, do anything" vehicle.

The Alu-Tech Construction System incorporates state of the art vehicle technology featuring an interlocking aluminium external framework that clamps the body panels together to produce a shell that is considerably stronger than one manufactured using traditional methods - strong enough, in fact, to support the weight of a typical family estate car!

The five part assembly – including a unique single piece front and roof section – makes the caravan more aerodynamic and ensures a smoother and more efficient ride. Its more balanced overall design – with a larger proportion of weight concentrated at the centre – makes the caravan inherently more stable enabling it to take even the most demanding journey in its stride.

And when you consider that all these benefits of ownership have been achieved without a weight penalty you can begin to see why the Alu-Tech construction system is so unique.

Built with practicality in mind the new Bailey Olympus is much more than just a high performance body shell. Models also come supplied with the latest road safety equipment, including the AL-KO ATC Trailer Control System, , an AL-KO AKS Stabiliser and AL-KO shock absorbers to ensure trouble-free towing, whilst the optional AL-KO Secure wheel lock provides added protection for your investment on site.



Bailey Alu-Tech trial of strength. Total load on caravan roof = 1,630 kgs



AL-KO ATC Trailer Control System &  
AL-KO AKS 3004 Stabiliser



AL-KO Shock Absorbers

**FIVE PART FULLY BONDED  
EXTERIOR PANEL ASSEMBLY SYSTEM**

**INTERLOCKING ALUMINIUM EXTRUSION  
EXTERNAL FRAMEWORK**

- PROVIDES STRUCTURAL SUPPORT
- NO EXTERNAL FIXING POINTS

SINGLE PIECE  
LAMINATED FRONT  
AND CEILING PANEL

LAMINATED  
SIDE AND  
BACK PANELS

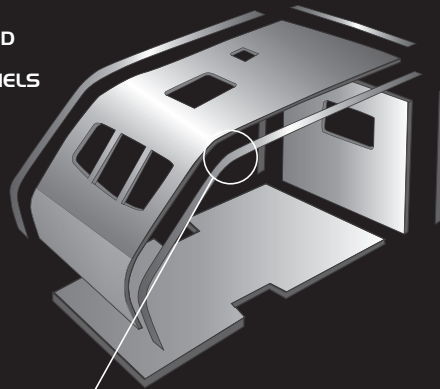
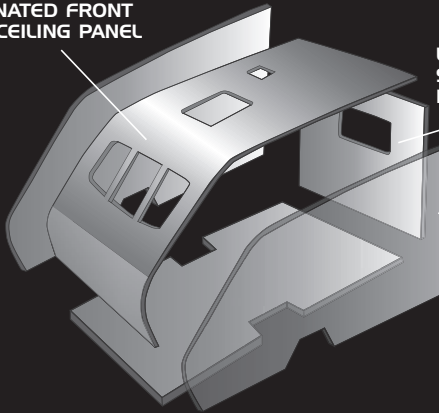

CARAVAN CEILING

METAL  
CONNECTING  
BRACKET

COVERING CAP TO  
HIDE FIXINGS AND  
CABLE TIDY

T BOLT FIXING BETWEEN  
BRACKET AND OUTER EXTRUSION

CARAVAN SIDE

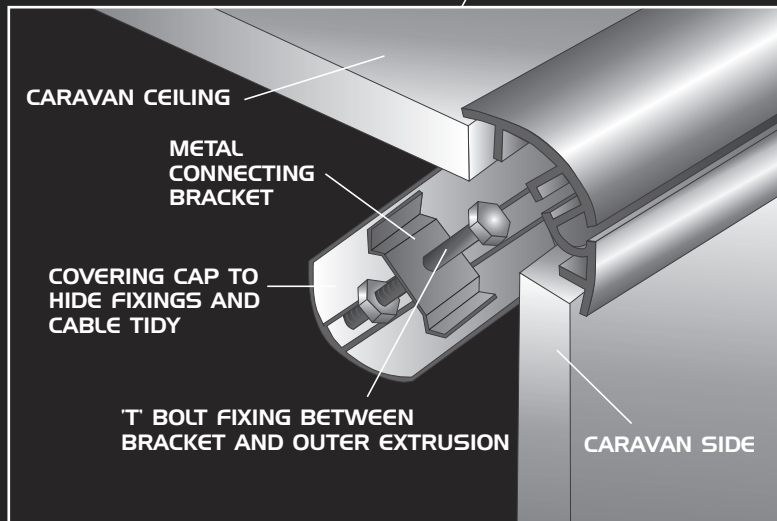



## COMFORT & PRACTICALITY

The first thing you will notice when you step inside an Olympus is the feeling of extra space. This is created by an increase in internal headroom which is now, thanks to the flat panel roof construction, a market leading 1.96m (6'5") throughout the length of the caravan.

A suite of floating fascia overhead lockers, with sturdy structural dividers, makes practical use of this additional height by maximising the high level storage capacity available.

The unique Alu-Tech body shell profile also produces extra room at the front of the caravan resulting in a more spacious lounge, featuring a window shelf wide enough to become a dedicated television station.



Market leading headroom 1.96m (6'5")



Olympus 534 in standard Monaco upholstery



Top left clockwise: Floating fascia overhead storage lockers, sculpted arm rests in wrap around configuration, wall mounted fabric magazine rack & high gloss kitchen worktop laminate



## COMFORT & PRACTICALITY

Packed with home comforts Olympus provides you with everything you will need for a relaxing and enjoyable holiday.

Well equipped kitchens feature a built in microwave, a spacious Thetford 107 litre refrigerator plus a re-engineered Spinflo 4-burner gas hob and large capacity sink as standard. Entertainment systems are upgraded too with the inclusion of a branded stereo Radio/CD/MP3 player with iPod connectivity, complete with dual cone speakers for superior sound quality.

Models are available in a choice of two contrasting soft furnishing schemes in a wrap around configuration and come supplied with a full compliment of arm rests and scatters. While superior quality cushion construction and fully sprung base supports ensures that this caravan is every bit as comfortable as it looks.

Contemporary furniture designs in the Bailey 'pear' finish are enhanced with the introduction of new high gloss worktop laminates and premium quality fixtures and fittings in matt nickel. This stylish

interior is shown to its best advantage by clear canopy maxi and mini Heki rooflights by day and a battery friendly low voltage LED lighting system by night.

In short Olympus has it all and, thanks to the Bailey trademark value for money package, it is now available for considerably less than you might think.

[www.baileyolympus.co.uk](http://www.baileyolympus.co.uk)



Olympus 462 in optional Andorra upholstery



Top left clockwise: Well equipped kitchens include a Thetford refrigerator, a Spinflo 4-burner gas hob, a large capacity Spinflo sink and a microwave oven as standard

# Product Specification

## Soft Furnishing Options



Standard Monaco upholstery



Optional Andorra upholstery



Drop in carpets

## ALU-TECH BODY SHELL

Supplied with a market leading **10-Year integrity guarantee\*** | Fully insulated shell to **Grade III** classification of EN1645-1

## CONSTRUCTION

Structural interlocking aluminium extrusion external framework with no external fixing points and an integral water management system | Five part fully bonded exterior panel assembly system featuring: Panel thicknesses of: **Sides 37mm, Ceiling 37mm & Floor 44mm** | Upper body panels manufactured using superior bead application laminating technology for a stronger more consistent bond | Upper body panels built using a timber free construction, incorporating a composite plastic internal skeleton, a high density polystyrene insulation and a GRP inner wall lining | Upper body panels incorporating low absorbency buffer zones surrounding window and door apertures | Upper body panels cloaked in a single sheet Impact resistant 3000 Series aluminium skin | Chip resistant paint protection film applied to caravan lower front | Colour coded components for improved aesthetics

## EXTERIOR FEATURES

**NEW** AL-KO galvanised steel chassis, braking system and running gear | AL-KO ATC Trailer Control System | AL-KO chassis mounted spare wheel carrier and spare wheel (steel spare wheel) | AL-KO AKS 3004 Stabiliser | AL-KO shock absorbers | 13 pin DIN standard caravan connecting cable | 14" Alloy wheels with low profile tyres | **NEW** two part large aperture Hartel door with moulded interior liner, window, blind and waste bin | **NEW** LED awning light with integral water management system | **NEW** Flush fit integral Polyvision double glazed windows with integral water management system to front | **NEW** Flush fit integral Polyvision double glazed windows to side and rear | **NEW** Flush fit integral exterior service doors | **NEW** Twin front wet locker storage compartments | **NEW** Weatherproof LED lit front grab handles for improved night time visibility | Central front gas locker compartment which will accommodate all bottle types and sizes

## INTERIOR FEATURES SPACE

**NEW** Internal headroom of 1.96m (6'5") throughout the length of the caravan

## FURNITURE & SOFT FURNISHINGS

**NEW** Large front window shelf (35cm wide) | Self supporting hinge sprung slatted bed box tops for ease of access | Sprung bed box slats for extra comfort | Pull out roller slatted bed | Seat and backrest ventilation boards | **NEW** Optional chest of drawer unit with slide out occasional table | Free standing table with dedicated storage | Occasional table (model specific) | Floating fascia overhead locker system with split level storage, domestic style metal hinges and concealed catches | **NEW** Structural locker dividers with greater load bearing capacity | Flush profile overhead locker doors | Streamlined caravan furniture units featuring flush fit doors | Solid partition doors to washroom with



\*Terms and conditions apply. 10-Year integrity guarantee comprises of 6 years standard warranty cover and 4 years extended warranty cover supplied free of charge. Please visit [www.baileyolympus.co.uk](http://www.baileyolympus.co.uk) for more information on the Olympus warranty package.

domestic standard metal handle | Solid partition doors to separate end bedroom (model specific) | **NEW** Bailey 'Pear' furniture veneer | **NEW** High gloss kitchen work top laminate | Premium quality fixtures and fittings in a nickel finish | Fully sprung upholstery (except split cushions used in bunk make up) featuring premium quality fabrics, high density filling and superior cushion construction | **NEW** Standard Monaco soft furnishings with co-ordinating curtains, shaped arm rests and scatter cushions in a wrap around configuration | **NEW** Optional Andorra soft furnishings with co-ordinating curtains, shaped arm rests and scatter cushions in a wrap around configuration | Loose fit drop in carpets

## SERVICES

### ELECTRICAL SYSTEM

230v power supply with three interior sockets | TV station with 230v/12v/aerial sockets | Status 530 telescopic directional television aerial | 12v internal lighting | Centrally located control panel | Domestic style consumer unit with dedicated access door | Switch mode battery charger with 20 amps output | RCD/MCB protection for mains electric system | 25 metre mains connecting lead

### WATER & GAS SYSTEM

Truma 3002 3kw gas heater with electronic ignition, silent running night setting and supplementary 230v Ultraheat system | Truma Ultratherm and blown air distribution system | Truma Ultrastore water heater (gas/electric operation) | Propane/Butane 30mb gas regulator mounted in gas locker compartment | Whale Aqua smart II on-board water pump | **NEW** Wheeled fresh water container with dedicated storage (capacity 23 litres) | Inboard pressurised hot and cold fresh water system with reinforced hosing | Inboard rigid pipe waste water plumbing system | Inboard shower unit with ceramic ball mixer tap | Fully lined shower cubicle (model specific) | Non-slip shower mat | Swivel Thetford C-250 cassette toilet with integrated header tank

### KITCHEN EQUIPMENT

**NEW** Thetford 107 litre refrigerator with full width freezer compartment | **NEW** Spinflo recessed 4-burner hob unit incorporating flush fitting glass hinged lid, conveniently located controls and rear splash back | Spinflo combined grill and domestic style glass fronted oven with electronic ignition and flame failure device | **NEW** Large capacity Spinflo recessed sink with removable draining board and ceramic ball mixer tap | Microwave oven | Chopping board | Washing up bowl

### GENERAL EQUIPMENT

**NEW** Horrex pleated flyscreen and sunblinds to all side and rear windows | Remis retractable flyscreen and sunblinds to all front windows | Horrex pleated full length flyscreen to exterior door | Full size Heki II tilting sunroof | **NEW** Mini Heki roof light located over kitchen area | Mini Heki roof light located over rear bedroom (model specific) | Branded Radio/CD/MP3 player with iPod/MP3 player connection point | Branded dual cone stereo speakers for superior sound quality

### SECURITY

AL-KO Secure prepared Euro-axle featuring lock receiver plate with optional AL-KO Secure portable wheel lock | CRiS identity number etched to windows and caravan chassis | Concealed security data chip within caravan construction



Optional chest of drawers with slide out table



Supplementary arm rests supplied as standard with Andorra upholstery and as a cost option with Monaco upholstery



Branded Radio/CD/MP3 player with iPod connectivity



Branded dual cone stereo speakers

**AL-KO AKS**

Stabiliser

**AL-KO ATC**

Trailer-Control

**AL-KO OCTAGON**

Shock Absorber

**AL-KO SECURE**

Wheel Lock

# Technical Specification



Olympus 504 in optional Andorra upholstery

	462	464	504	525	534	546	624
Berths	2	4	4	5	4	6	4
Internal Length	4.579m 15'0"	4.779m 15'8"	5.678m 18'8"	5.528m 18'2"	5.678m 18'8"	5.528m 18'2"	6.292m 20'8"
Shipping Length	6.152m 20'2"	6.352m 20'10"	7.251m 23'9"	7.101m 23'4"	7.251m 23'9"	7.101m 23'4"	7.865m 25'10"
Overall Width	2.19m 7'2"	2.19m 7'2"	2.19m 7'2"	2.19m 7'2"	2.19m 7'2"	2.19m 7'2"	2.19m 7'2"
Overall Height	2.63m 8'8"	2.63m 8'8"	2.63m 8'8"	2.63m 8'8"	2.63m 8'8"	2.63m 8'8"	2.63m 8'8"
Internal H'room	1.96m 6'5"	1.96m 6'5"	1.96m 6'5"	1.96m 6'5"	1.96m 6'5"	1.96m 6'5"	1.96m 6'5"
Awning Size	936cm	956cm	1046cm	1031cm	1046cm	1031cm	1113cm
Tyre Sizes	195/70 R14 96N	185 R14 L1104	185 R14 L1104	185 R14 L1104	185 R14 L1104	185 R14 L1104	185/65 R14 L193N
MTPLM	1263kg 24.9cwt	1320kg 26.0cwt	1440kg 28.4cwt	1463kg 28.8cwt	1458kg 28.7cwt	1457kg 28.7cwt	1618kg 31.8cwt
MRO	1078kg 21.2cwt	1125kg 22.1cwt	1224kg 24.1cwt	1238kg 24.4cwt	1242kg 24.4cwt	1222kg 24.1cwt	1395kg 27.5cwt
Payload Allownce for Essnt Habt'n Equipment	68kg 1.3cwt	68kg 1.3cwt	68kg 1.3cwt	68kg 1.3cwt	68kg 1.3cwt	68kg 1.3cwt	68kg 1.3cwt
Payload Allownce for Personal Effects	102kg 2.0cwt	124kg 2.4cwt	133kg 2.6cwt	142kg 2.8cwt	133kg 2.6cwt	152kg 3.0cwt	140kg 2.7cwt
Payload Allownce for Optional Equipment	15kg 0.3cwt	3kg 0.1cwt	15kg 0.3cwt	15kg 0.3cwt	15kg 0.3cwt	15kg 0.3cwt	15kg 0.3cwt
Total User Payload	185kg 3.6cwt	195kg 3.8cwt	216kg 4.3cwt	225kg 4.4cwt	216kg 4.3cwt	235kg 4.6cwt	223kg 4.4cwt

## Bed sizes

**462**  
Front Double 6'6" x 6'3"  
Or 2 @ 6'3" x 2'3"

**464**  
Front Double 6'6" x 4'6"  
Rear Double 6'4" x 4'6"

**504**  
Front Double 6'6" x 5'4"  
Or 1 @ 5'4" x 2'3"  
Or 1 @ 5'6" x 2'3"  
Rear Double 6'4" x 4'6"

**525**  
Front Double 6'6" x 5'6"  
Or 2 @ 5'6" x 2'3"  
Rear Double 6'6" x 4'5"  
Rear O/Head Single 6'0" x 2'0"

**534**  
Front Double 6'6" x 5'4"  
Or 1 @ 5'4" x 2'3"  
Or 1 @ 5'6" x 2'3"  
Rear Double 6'4" x 4'6"

**546**  
Front Double 6'6" x 5'7"  
Or 2 @ 5'7" x 2'3"  
3 Rear Bunks 6'0" x 2'1"  
1 Rear Bunk 5'7" x 2'6"

**624**  
Front Double 6'6" x 5'10"  
Or 2 @ 5'10" x 2'3"  
Rear Double 6'4" x 4'6"

# Model Range

462 - 2 Berth

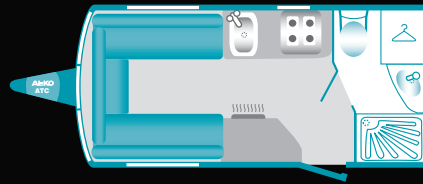

464 - 4 Berth

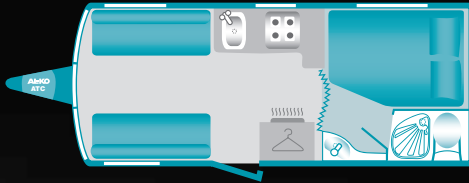

504 - 4 Berth (NEW LAYOUT)

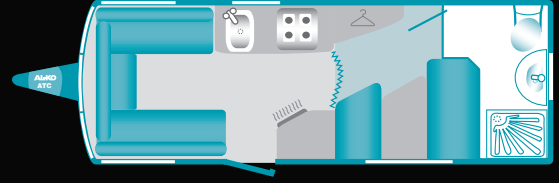

525 - 5 Berth

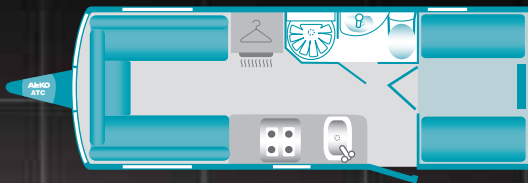

534 - 4 Berth

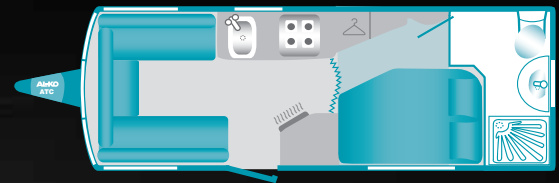

546 - 6 Berth

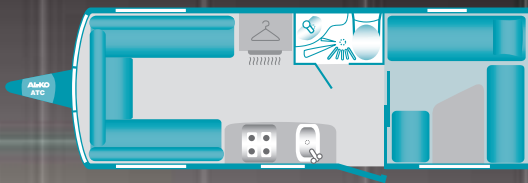

624 - 4 Berth (TWIN AXLE)

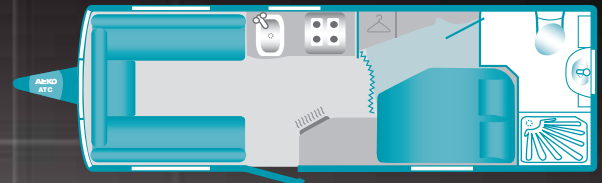

360° Product Tours for all layouts can be viewed on the Olympus micro site @ [www.baileyolympus.co.uk](http://www.baileyolympus.co.uk)



Olympus 546 in optional Andorra upholstery & Olympus 534 washroom

# OLYMPUS -

*one day, all caravans will be made this way*



Olympus 464 in standard Monaco upholstery

[www.bailey-caravans.co.uk](http://www.bailey-caravans.co.uk)

South Liberty Lane, Bristol BS3 2SS, England

This brochure does not constitute an offer by Bailey Caravans Ltd (Bailey). Bailey reserves the right to alter specifications and prices as market and supply conditions demand. Your Bailey retailer will confirm all specification details prior to you making your purchasing decision. E. & O. E. Bailey retailers sell our products of their own choice and not as agents of Bailey. Accordingly they have no authority to bind Bailey or to make any representation or undertaking whatsoever on behalf of Bailey. All household items illustrated in this brochure are used to enhance photography and are for display purposes only. They are not supplied with your touring caravan. Photographic colour reproduction is subject to the limitations of the production process.

Design: trm:vs Photography: Alan Bond Print: Kingsdown Printers Issued February 2010



80% Recycled paper

