

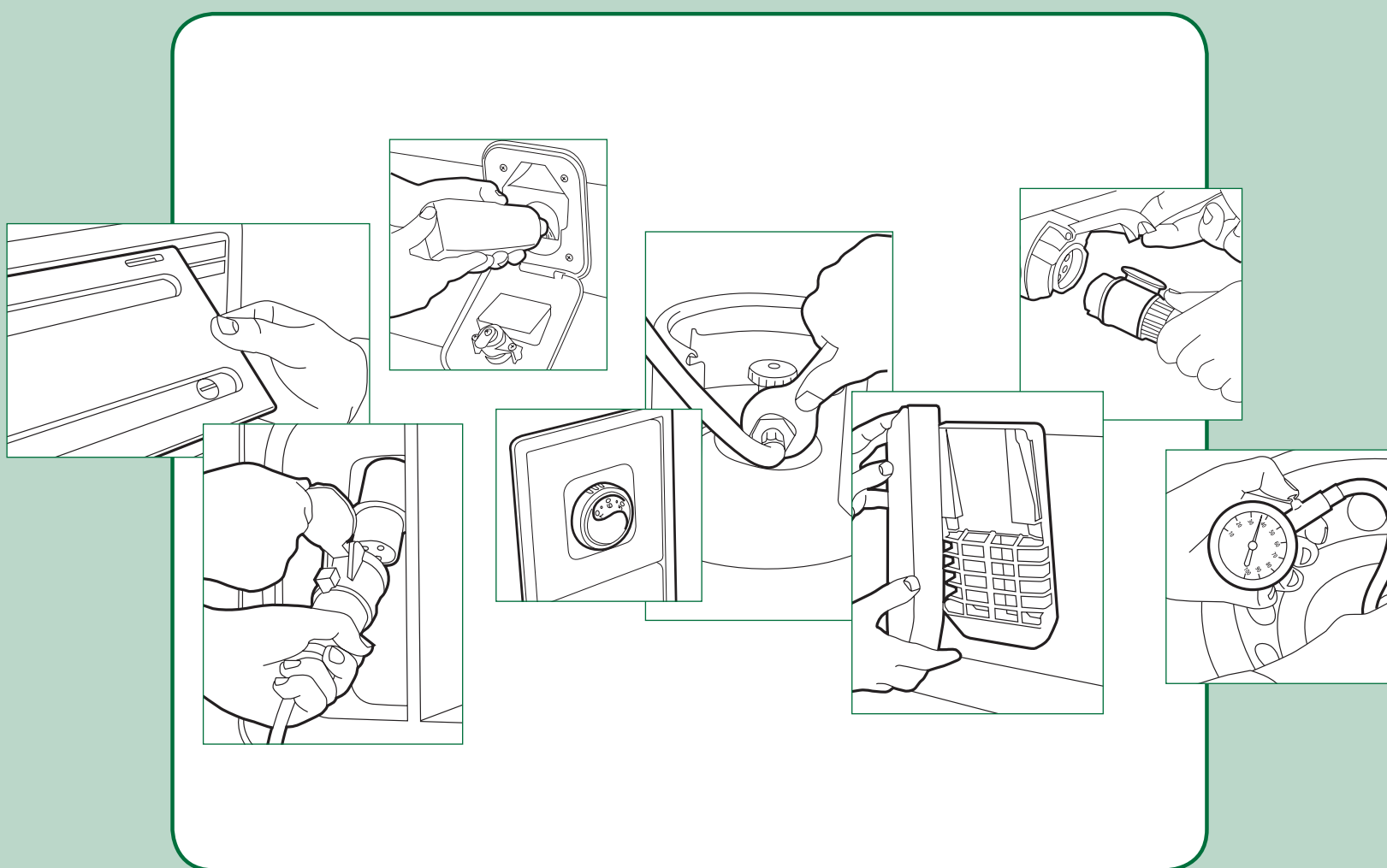

# Bailey of Bristol



## Caravan Quick Start Guide

Please note: The Quick Start Guide is intended to be used in conjunction with the Caravan Owner's Manual and not as a substitute

# GETTING READY

## Handbook Section Ref.

Section 2.2.6

### LOADING

- Secure the heaviest items at floor level positioned centrally over the caravan axle.

Service Handbook

### TYRE PRESSURES

- Check your tyre pressures are correct before commencement of your journey.

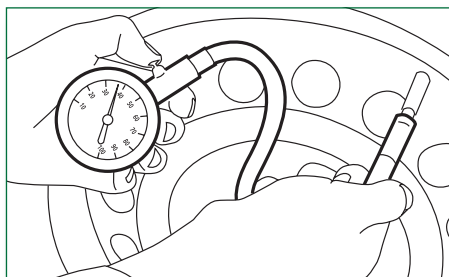

Section 2.2.8

### WHEEL FIXINGS

- Check the wheel bolts are tightened to the correct torque setting before the commencement of your journey (using a calibrated torque wrench).

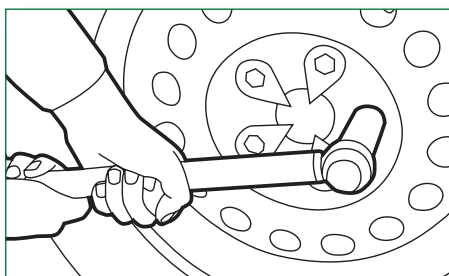

Section 2.2.9

### HITCHING UP YOUR VEHICLE

- When you've coupled-up your caravan, check that the green section of the safety button on the coupling head is visible to verify there's a secure union with the tow ball.

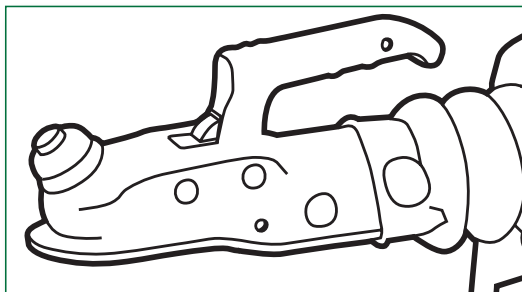

Ranger

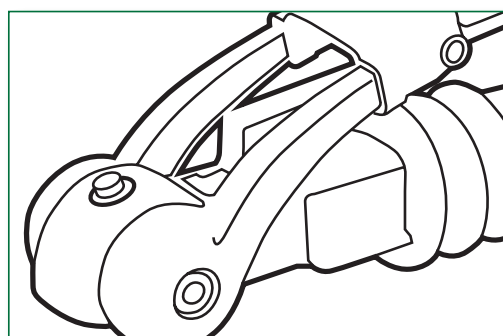

Ranger GT60  
Pageant  
Olympus  
Pegasus

Section 2.2.9

- Ensure the break away cable is attached to your tow vehicle prior to departure.

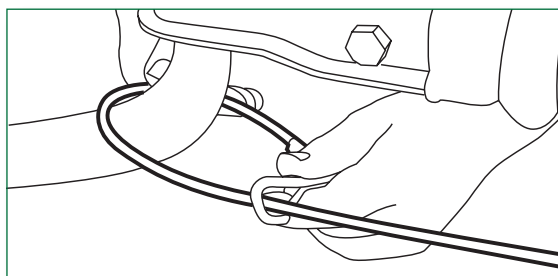

# GETTING READY (Contd)

Section 2.2.9

## ROAD LIGHTS

- Your caravan will be fitted with a single 13 pin connector. If the receiving sockets on the car do not match the lead on the caravan an adaptor will be required. In both cases connect the relevant leads and check that your caravan road lights are operating correctly.

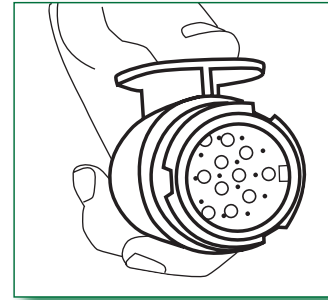

Single  
13 pin  
connection

Section 4.13

## STABILITY CONTROL SYSTEM

- Some units are now fitted with the AL-KO Trailer Control System. To engage the system plug in the grey lead to the correct socket on the rear of the tow vehicle. Once connected the system will self-test once and the green LED light on the a-frame cover will come on. If a red light appears the ATC system is not functioning correctly. To disengage the system unplug the grey lead and the caravan brakes will operate in the normal manner.

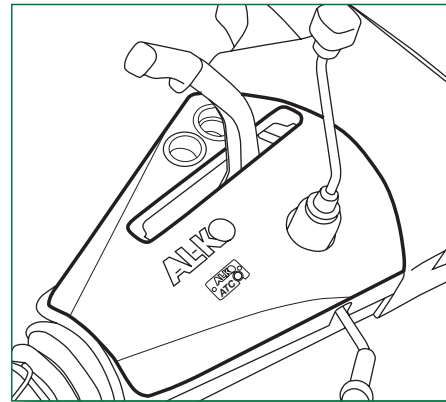

# ARRIVAL

Handbook Section Ref.

## SITING THE CARAVAN

- Try to situate your caravan away from trees and consider features like views, ease of access and the influence of the sun.

## LATERAL LEVELLING

- If the caravan needs elevating on one side, tow it on to a board (or two) in order to bring it level in the side to side plane.

Section 2.3.17

## UNCOUPLING

- Fully apply the caravan's hand brake, chock the wheels, unclip the break away cable, disconnect the electrical plugs and lift the caravan clear of the towball by winding the jockey wheel handle.

Section 2.3.18

## FORE AND AFT LEVELLING

- When you've got your caravan level from front to back by using the jockey wheel, lower the corner steadies on to some pads or boards to stop them digging into the pitch surface.

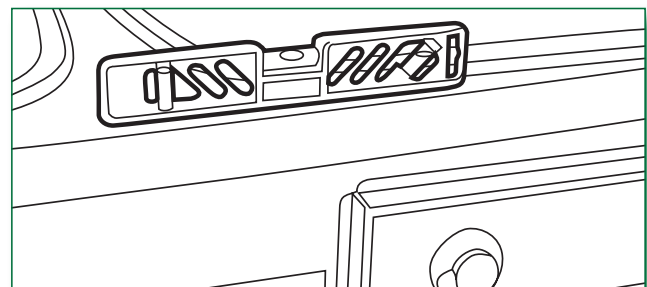

# CONNECTING UP

## Section 3.3

### MAINS POWER CONNECTION (230V)

- Couple up the mains supply if you're using a pitch with a 230V hook-up (A&B).
- Turn on RCD and MCB switches on the Mains Consumer Unit located under front bed box (C).

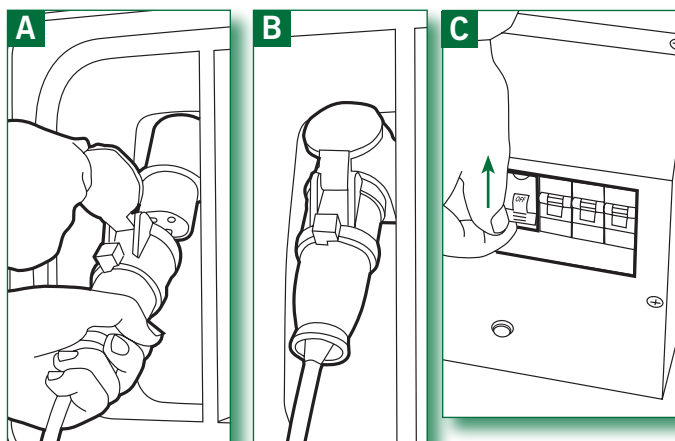

## Section 3.4

### BATTERY POWER SUPPLY (12v)

- The 12V leisure battery should have already been connected by your retailer, if not, follow the procedure in Section 3.4.2.
- On your 12V control panel, switch the 12V master control to its ON Position (B).

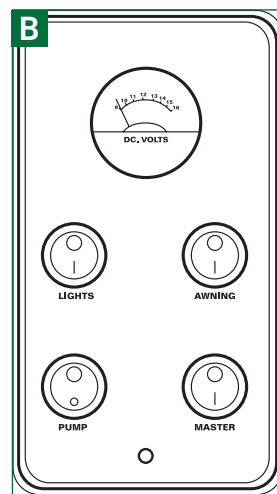
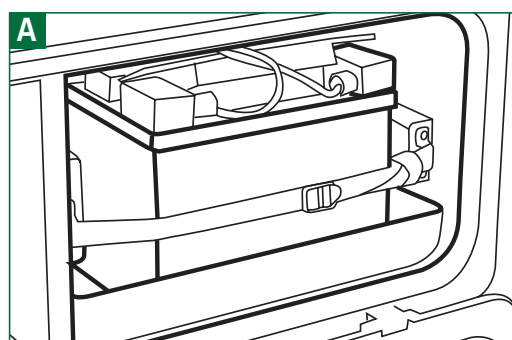

## Section 3.2

### GAS SUPPLY

- Turn on the gas supply at the cylinder and also the supply taps which serve individual appliances. Bear in mind that if there's still some air in the supply pipes, the ignition of gas equipment might take longer than usual.

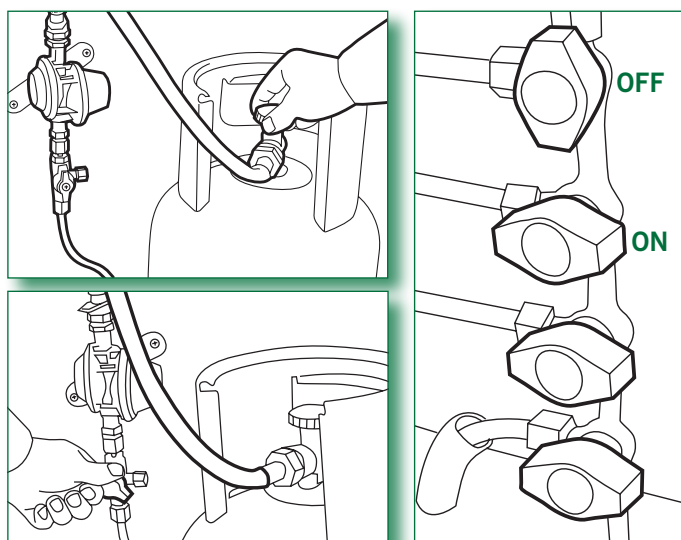

# CONNECTING UP (Contd)

## Handbook Section Ref.

### Section 3.1

If you have the optional Aquasource Direct Mains Water Connection facility, see Section 3.1.11 of your Owners Manual

### FRESH WATER

- Close all the taps.
- Close the yellow water heater drain-down tap located next to the water heater unit (A).
- Fill the water container, lower the submersible pump under the surface and then push the hose coupling firmly into the socket on the wall of your caravan (B&C).
- Turn on the pump switch at the control panel (D).
- Open the kitchen tap and push the lever to hot. Allow the air in the system to escape until a steady flow of water is attained. The system is now pressurised and the tap can be closed.
- Repeat operation for the washroom handbasin tap.

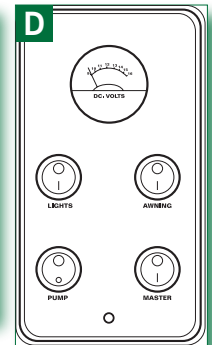
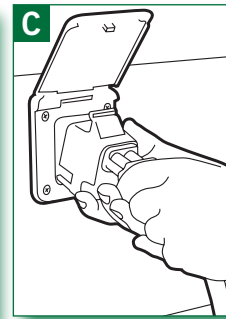
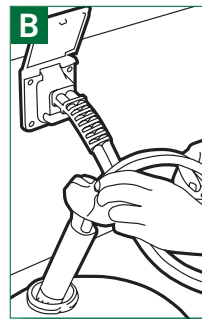
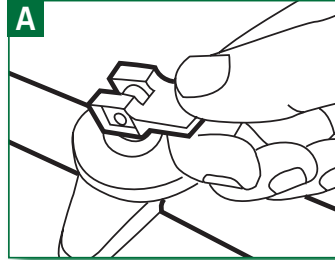

Section 3.1.4  
(Olympus & Pegasus  
Owners Manual)

- Olympus and Pegasus models also have an on-board fresh water tank. Please refer to the Owners Manual for operation.

### Section 3.1.15

### WASTE WATER

- Couple-up two waste water hoses to the outlet which is fitted just to the rear of the offside wheel; then direct the hoses into a suitable holding container.

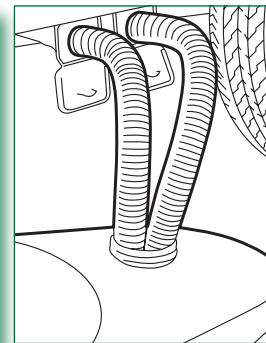
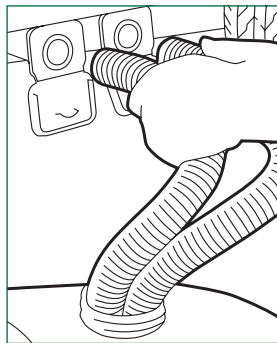

Section 3.1.12  
(Olympus & Pegasus  
Owners Manual)

### Section 4.11

### CASSETTE TOILET

- Withdraw the cassette (A) and add the appropriate dose of Green chemical treatment (B) together with two litres of water via the spout.
- To fill the flush tank under the filler cap located above the toilet cassette door with your caravan key.
- Add the required dose of Pink flush chemical (C) and top up with water (D).

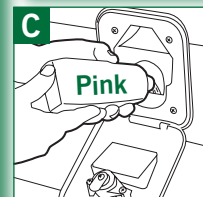
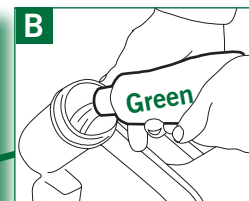
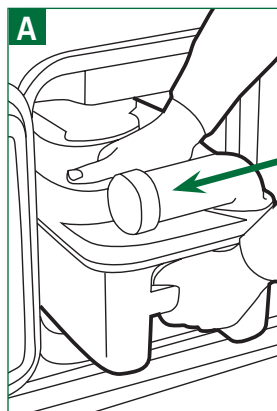

Section 4.10  
(Olympus & Pegasus  
Owners Manual)

# SWITCHING ON APPLIANCES

## Handbook Section Ref.

Section 4.8 to  
Section 4.10

### REFRIGERATOR

- Decide whether to run your refrigerator on either gas or mains electricity and then switch it to your preferred operating mode according to the instructions in your Owner's Manual.

Section 4.1

### WATER HEATER

- Ensure the water heater is full and remove its exterior cover (A) then decide whether to run it on a gas supply or a 230V supply.
- To run on gas rotate the dial (B) clockwise to start up the water heater. This may need 2 or 3 attempts to purge the gas system of air. Once operational set the required temperature (B).
- To run on 230V electric turn on the fuse spur switch labelled water heater (there is no temperature control for 230V operation) (C).
- Note: To achieve a fast heat-up from cold, your Ultrastore heater can be operated on gas and mains power simultaneously.

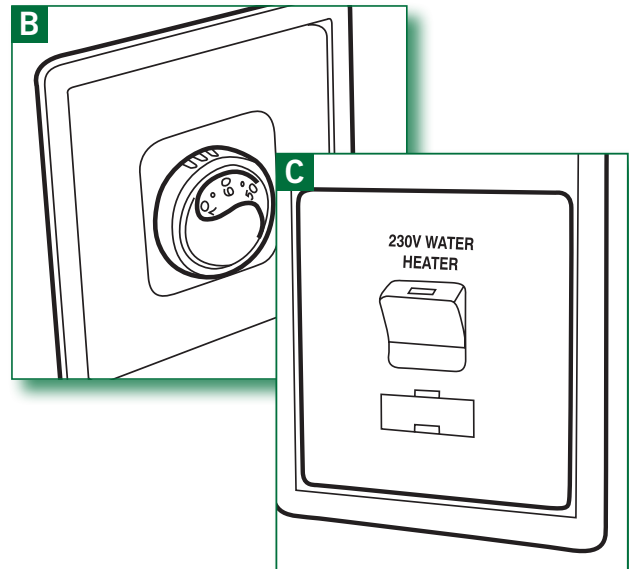
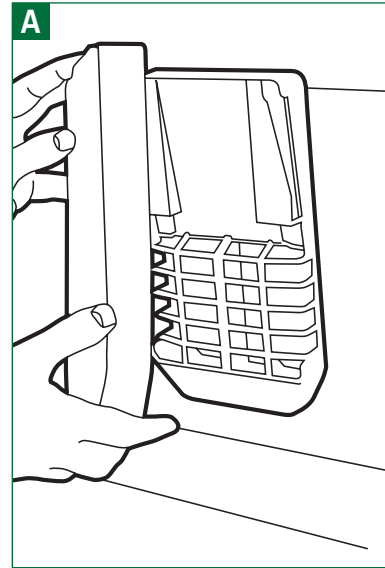

# SWITCHING ON APPLIANCES (Contd)

## Section 4.2

See safety guidance and operation procedures in Section 4.2

### SPACE HEATER (230v/12v/Gas)

- It is permissible to operate your Truma S 3002 EL space heater on either gas, mains electricity, or both simultaneously.
- To operate on gas, ensure the supply tap is on and ignite the space heater via the controls mounted on the top of the fire front cover.
- To operate the supplementary 230V heating turn the fuse spur (A) to the ON position. Then rotate the control panel (B) to the required power setting, 500, 1000 or 2000 watts. Then set the temperature on the rotating dial in the centre of the control.

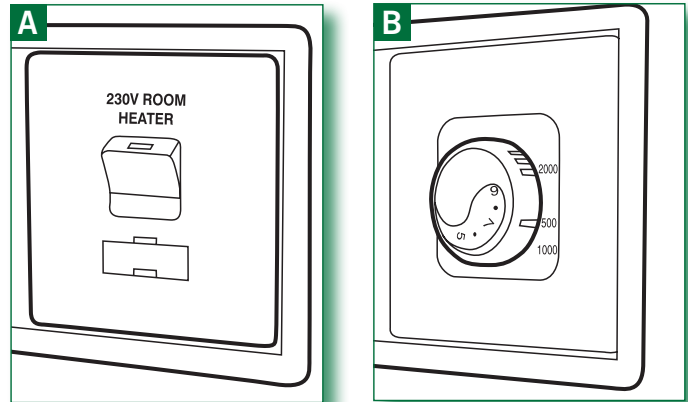

## Handbook Section Ref.

### Section 4.5

#### HOB

- Note the Do's and Don'ts in Section 4.6.4 and follow the guidance on ignition procedures given in Section 4.5.1

### Section 4.6.1

#### GRILL

- Ensure the grill pan is put into place to protect the base lining of the compartment and follow instructions on lighting the appliance given in your Owners Manual.

### Section 4.6.2

#### OVEN

- Full guidance on lighting the oven together with user hints and tips given in Section 4.6.3

# PREPARING TO LEAVE

Section 2.2.8

## SWITCHING OFF APPLIANCES

- Switch off all the appliances, together with switches on the 12V control panel (A) and the RCD and MCB switches on the Mains Consumer Unit (B).  
Select 12V operation on your refrigerator.

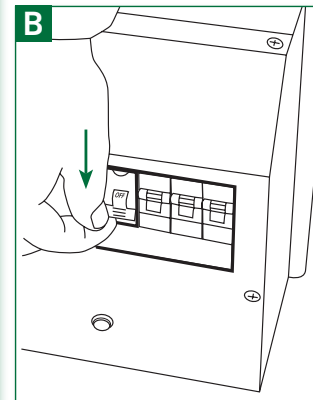
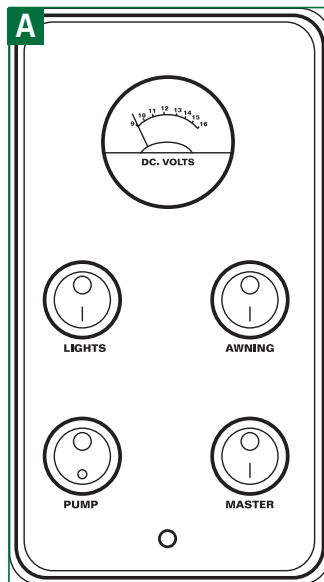

See text

## DISCONNECTING SERVICES

- Disconnect the mains supply (Section 3.3.2), turn off the gas supply, remembering to do this at the supply taps and at the cylinder (Section 4.1.3), the waste water discharge system, the fresh water supply system (Section 3.1.12) and empty the water heater (Section 4.1.5).
- To travel with the minimum amount of weight on board, you are advised to drain down the water heater before leaving the site.

Section 2.2.8

## STOWING POSSESSIONS & CLOSING DOWN

- Securely stow all your possessions, close all cupboards, external and toilet cassette doors, lockers, internal doors, windows and skylights.
- Couple-up to the car and enjoy the journey!

